

# Salt Spray Chamber - WIN SERIES



## Model No. SSC – Win series

**Salt Spray Chamber Win Series** is a consistent tool useful for checking the corrosion resistance of surface coatings when exposed to atmospheric conditions. This instrument provides simulation of real time weathering conditions and designed to assess the ability of rust proofed components to withstand corrosion.

- Chamber temperature settings through PID Control
- Preset Timer functions incorporated for accuracy and repeatability
- Corrosion Resistant PT-100 sensor
- Solid state digital Programmable Temperature Controller
- Robust Construction with Fiber reinforced body.
- Hour meter to record cumulative number of hours run
- Microprocessor based PID controller
- External Reservoir Tank with stand

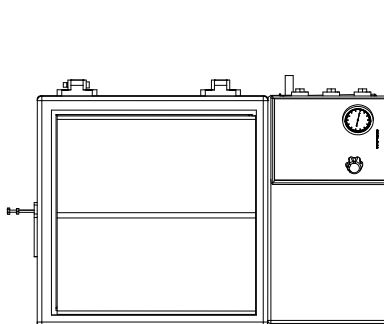

Top View

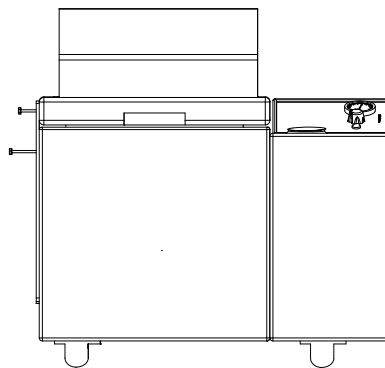

Front View

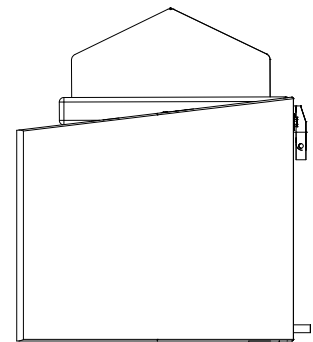

Side View



The Presto Salt Spray Tester has been designed strictly to assess the ability of rust proofed components to withstand corrosion due to atmospheric conditions.

#### Key Specifications :

Chamber Temperature Range	Ambient to 35°C
Chamber Temperature Least Count	0.1°C
Chamber Temperature Repeatability	± 2°C
Power	220V , Single phase, 50 Hz, 15 A
pH value of Salt Solution	6.5 to 7.2
Temperature Control	Inbuilt PID Temperature Controller
Timer (Hour meter)	6 Digits
Test Air Pressure	0.7Kg/cm <sup>2</sup> - 1.2Kg/cm <sup>2</sup>
Air Regulator	0 to 30 psi

#### Highlights:

NACL Reservoir Tank	100 Ltr. Capacity (External Tank)
Material	Fiber Glass
Over Temperature Alarm	Yes

#### Note:

**Compressed air requirement :** Approx. 7 cfm in (Air compressor not part of supply)  
Main air line pressure regulator with filter and wasted water drain provision in customer scope.

#### Specifications :

	Win Series 250 W	Win Series 450 W
<b>CONSTRUCTION</b>		
Dimensions Internal / External	800x500x550 mm / 1550x960x1240 mm	1000x700x750 mm / 1740x1150x1550 mm
Insulation	High grade glasswool Insulation	High grade glasswool Insulation
NACL Tank	External Tank with stand only	External Tank with stand only
FRP Material	√	√
Double Walled	√	√
<b>PARAMETERS</b>		
Capacity Lit.	250	450
Chamber Temp. max. °C	40	40
Tolerance °C	± 2	± 2
Air Pressure max. bar	2	2
<b>CONTROLS</b>		
Digital	√	√
Air Regulator & Gauge	√	√
High Temp. Alarm	√	√
<b>SPRAY System</b>		
Upright Tower	√	√
Removable Collar	√	√
<b>OTHER</b>		
Fog Collector Internal	√	√
<b>OPTIONS</b>		
PH Meter	O	O
Humidity Sensor & Indicator	O	O
<b>Legend</b>	√: Standard Supply O: Optional	

#### Head Office : Presto Stantest Private Limited

I-42, DLF Industrial Area Phase-I, Delhi Mathura Road, Faridabad 121003, Haryana, India  
P : +91 129 4272727 E : info@prestogroup.com

#### Branches :

##### Mumbai

503-504B, Fair link Centre, Opp. Fame Adlab  
Behind Mongini's Off Link Road  
Andheri (West), Mumbai 400058  
P : +91 022 42957052, 42957053  
E : west@prestogroup.com

##### Kolkata

93, 3<sup>rd</sup> Floor, Karnani Estate  
209, A.J.C. Bose Road  
Kolkata-700017. West Bengal  
P : +91 033 40612012  
E : east@prestogroup.com

##### Chennai

A-3, First Floor, Sri Sathya Sai Building  
755, Poonamallee High Road, Kilpauk  
Chennai- 600 010. Tamil Nadu  
P : +91 044 43865260, 43838372  
E : south@prestogroup.com

